

Gas and air filter

GF/1

Rp 1/2 - Rp 2

GF/3

DN 40 - DN 100

GF

DN 125 - DN 200

DUNGS[®]
Combustion Controls

11.02



Technical description

Filter for interior gas lines as per DIN 3386 with high dust storage capacity.

GF/1: Threaded connection as per ISO 7/1.

GF/3 and GF: Flange connection as per DIN 2501 Part 1 to fit preweld flange as per DIN 2633 corresponding to ISO 7005-2.

Max. flow rate: 20 m/s.

Installation option for pressure measurement point for filter monitoring.

Application

Type GF/1, GF/3 and GF gas and air filter for protecting downstream fittings. Filter suitable for gases of families 1,2,3 and other neutral gaseous media.

Approvals

EC type test approval as per EC Gas Appliance Directive:

GF .../1 CE-0085 AQ0121

GF .../3 CE-0085 AQ7127

GF 40125...40200 CE-0085 AQ7127

EC type test approval as per EC Pressure Equipment Directive:

GF 40125...40200 CE0045

Approvals in other important gas consuming countries.

Specifications - Threaded version

Nominal diameter	DN 15 Rp 1/2 as per ISO 7/1	DN 20 Rp 3/4	DN 25 Rp 1	DN 40 Rp 1 1/2	DN 50 Rp 2
Max. operating pressure	GF 5.../1 GF 40.../1	0.5 bar 4.0 bar			
Max. flow rate	≤ 20 m/s				
Ambient temperature	-15 °C to +80 °C				
Pore width of filter element	≤ 50 µm				
Measuring/ignition gas connection	GF 5.../1: G 1/4 screw connection as per DIN ISO 228 upstream and downstream of filter element, on housing cover GF 40.../1: G 1/4 screw plugs as per DIN ISO 228 upstream and downstream of filter element, on housing cover				
Materials	Housing	aluminium cast			
	Seals	NBR			
	Random laid nonwoven fabric	PP, PE			
	Filter holder	POM			
Installation position	Any, preferred position: with cap vertical				

Functional description

Filter designed for installation in interior gas lines and compressed air lines to protect downstream fittings. Filter element made of random laid nonwoven polypropylene fabric and metal support frame with pore width of ≤ 50 µm. Dust, chips and rust as well as other physical gas-accompanying materials and fouling are retained using the random laid nonwoven fabric. If the dust storage capacity is exceeded or if there is an excessive pressure difference, the filter loses its protective function.

Installation

Refer to gas flow direction indicated by arrow on filter housing. Provide sufficient space for changing the filter element. If the filter cap is mounted in vertical position, it is easier to clean the filter housing. After installation, perform leak test.

 **Avoid direct contact between hardening masonry, concrete walls, floors and filter.**

Change filter element

- At least once a year
- If pressure difference has increased by 100 % compared to new filter
- When pressure difference exceeds 50 mbar

Filter monitoring

GF 5.../1: The G 1/4 screw plugs can be replaced by suitable screw connections. Connect an gas differential pressure switch to monitor the pressure difference.

Gas filter with differential pressure switch

- A** G 1/4 screw connection **only** GF 5.../1
B Differential pressure switch for gas

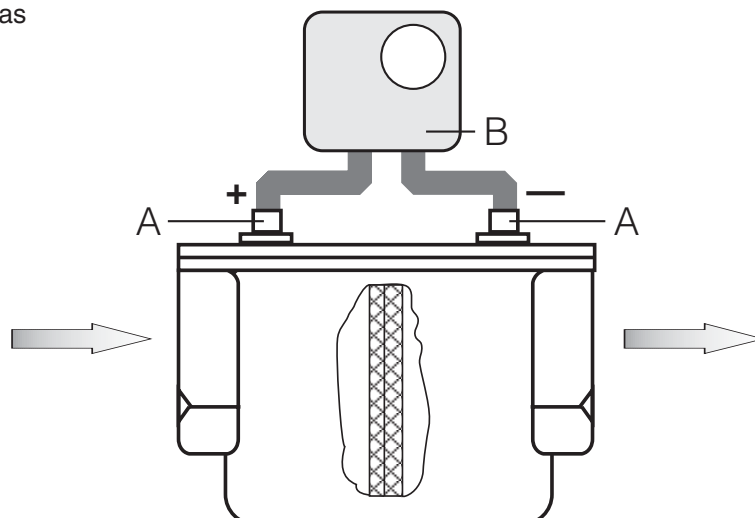

Dimensions (mm) - Threaded version

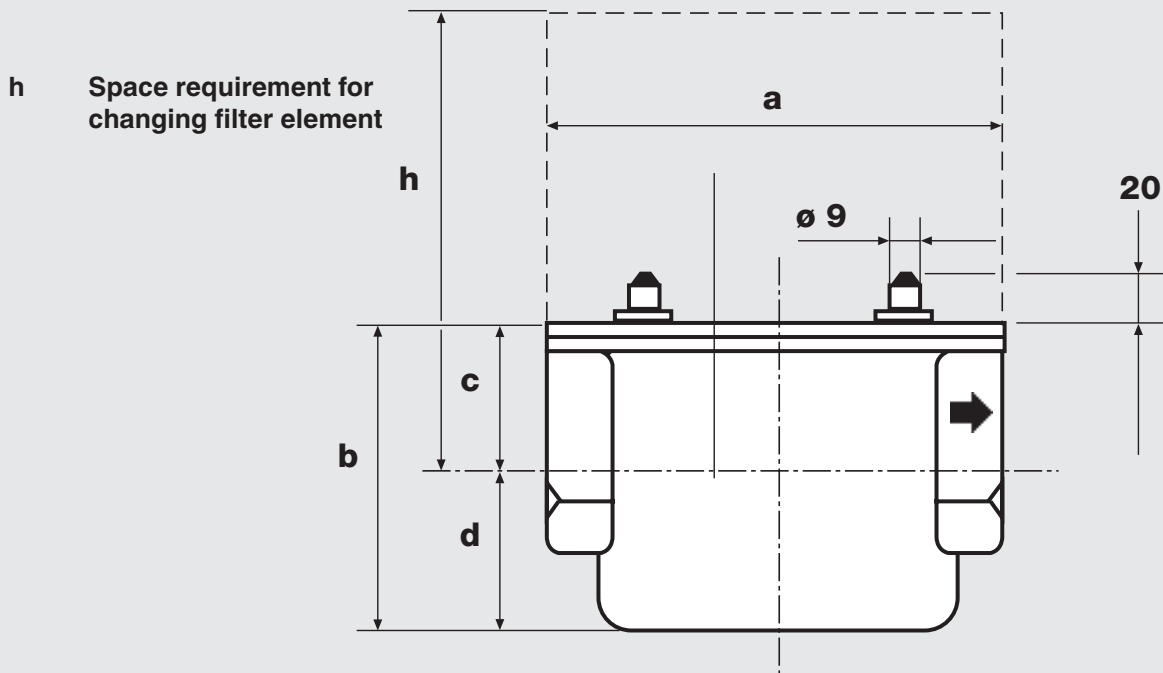

Type	Order No.	Max. operating pressure [bar]	connection Rp	Design	Dimensions [mm]					Weight [kg]
					a	b	c	d	h	
GF 505/1	066 191	0.5	Rp 1/2	MS	120	90	35	55	125	0.7
GF 507/1	066 209	0.5	Rp 3/4	MS	120	90	35	55	125	0.7
GF 510/1	066 217	0.5	Rp 1	MS	160	105	54	51	159	1.1
GF 515/1	066 225	0.5	RP 1 1/2	MS	160	105	54	51	159	1.1
GF 520/1	066 233	0.5	Rp 2	MS	186	140	75	65	215	1.9
GF 4005/1	228 073	4.0	Rp 1/2	VS	120	90	35	55	125	0.7
GF 4007/1	228 074	4.0	Rp 3/4	VS	120	90	35	55	125	0.7
GF 4010/1	228 075	4.0	Rp 1	VS	160	105	54	51	159	1.1
GF 4015/1	228 076	4.0	Rp 1 1/2	VS	160	105	54	51	159	1.1
GF 4020/1	228 077	4.0	Rp 2	VS	186	140	75	65	215	1.9

MS = screw connection
VS = screw plug

Specifications - Flanged version

Nominal flange size	DN 40 DN 50 DN 65 DN 80 DN 100 DN 125 DN 150 DN 200	
	Flange connection as per DIN 2501 Part 1 to fit preweld flange as per DIN 2633 (PN 16), ISO 7005-2 (PN 16).	
Max. operating pressure	4.0 bar	
Max. flow rate	≤ 20 m/s	
Ambient temperature	-15 °C to +80 °C	
Pore width of filter element	≤ 50 µm	
Measuring gas connection	G1/4 screw plugs as per DIN ISO 228 upstream and downstream of filter element, on left of housing	
Materials	Housing Seals Random laid nonwoven fabric Support frame	aluminium cast NBR PP Stainless steel
Installation position	Any, preferred position: with cap vertical	

Functional description

Filter designed for installation in interior gas lines and compressed air lines to protect downstream fittings. Filter element made of random laid nonwoven polypropylene fabric and metal support frame with pore width of ≤ 50 µm. Dust, chips and rust as well as other physical gas-accompanying materials and fouling are retained by the random laid nonwoven fabric. If the dust storage capacity is exceeded or if there is an excessive pressure difference, the filter loses its protective function.

Installation

Refer to gas flow direction indicated by arrow on filter housing. Provide sufficient space for changing the filter element. If the filter cap is mounted in vertical position, it is easier to clean the filter housing. After installation, perform leak test.

⚠ Important: Avoid direct contact between hardening masonry, concrete walls, floors and filter.

Change filter element

- At least once a year
- If pressure difference has increased by 100% compared to new filter
- When pressure difference exceeds 50 mbar

Filter monitoring

The G 1/4 screw plugs can be replaced with suitable screw connections. This permits the connection of an gas differential pressure switch to monitor pressure difference.

GF .../3 gas filter section

- 1 O ring
- 2 Cover
- 3 Housing
- 4 Filter element

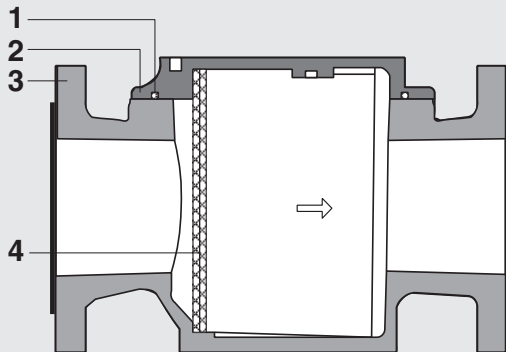

Filter monitor

- A** Measurement connection
B Differential pressure switch for gas

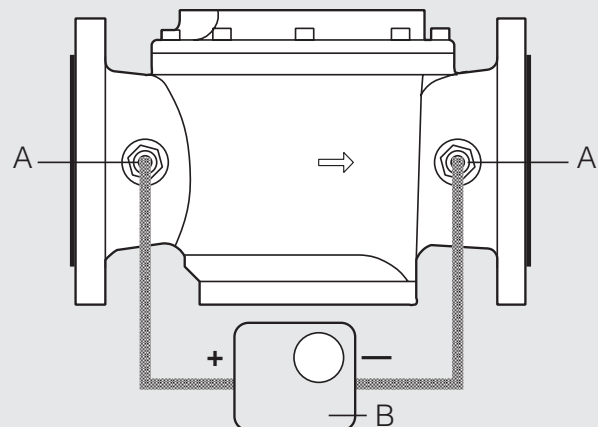

Dimensions (mm) - Flanged version

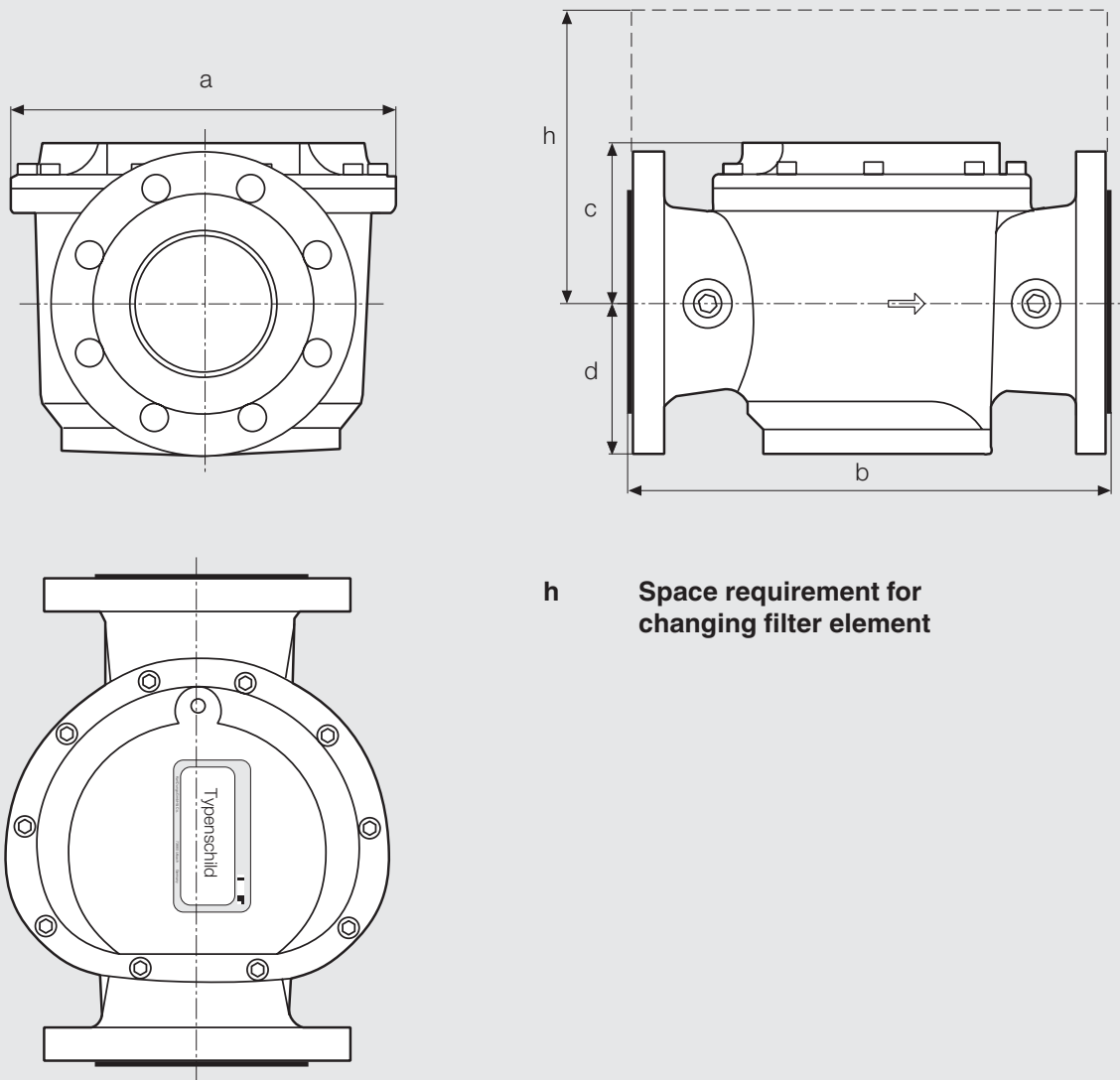

h Space requirement for changing filter element

Type	Order No.	Max. operating pressure [bar]	DN connection	Dimensions [mm]					Weight [kg]
				a	b	c	d	h	
GF 40040/3	222 637	4.0	DN 40	132	195	49	47	96	2.8
GF 40050/3	222 638	4.0	DN 50	159	211	69	50	119	3.6
GF 40065/3	222 639	4.0	DN 65	194	256	93	95	188	5.7
GF 40080/3	222 640	4.0	DN 80	234	294	105	101	206	7.9
GF 40100/3	222 641	4.0	DN 100	281	353	119	110	229	11.8
GF 40125	218 162	4.0	DN 125	281	360	182	183	365	19.5
GF 40150	218 163	4.0	DN 150	281	385	257	259	516	25.5
GF 40200	218 164	4.0	DN 200	388	455	236	239	475	40.0

Volumetric flow/pressure drop characteristic

Pressure loss Δp [mbar] for natural gas ($dv = 0,64$)

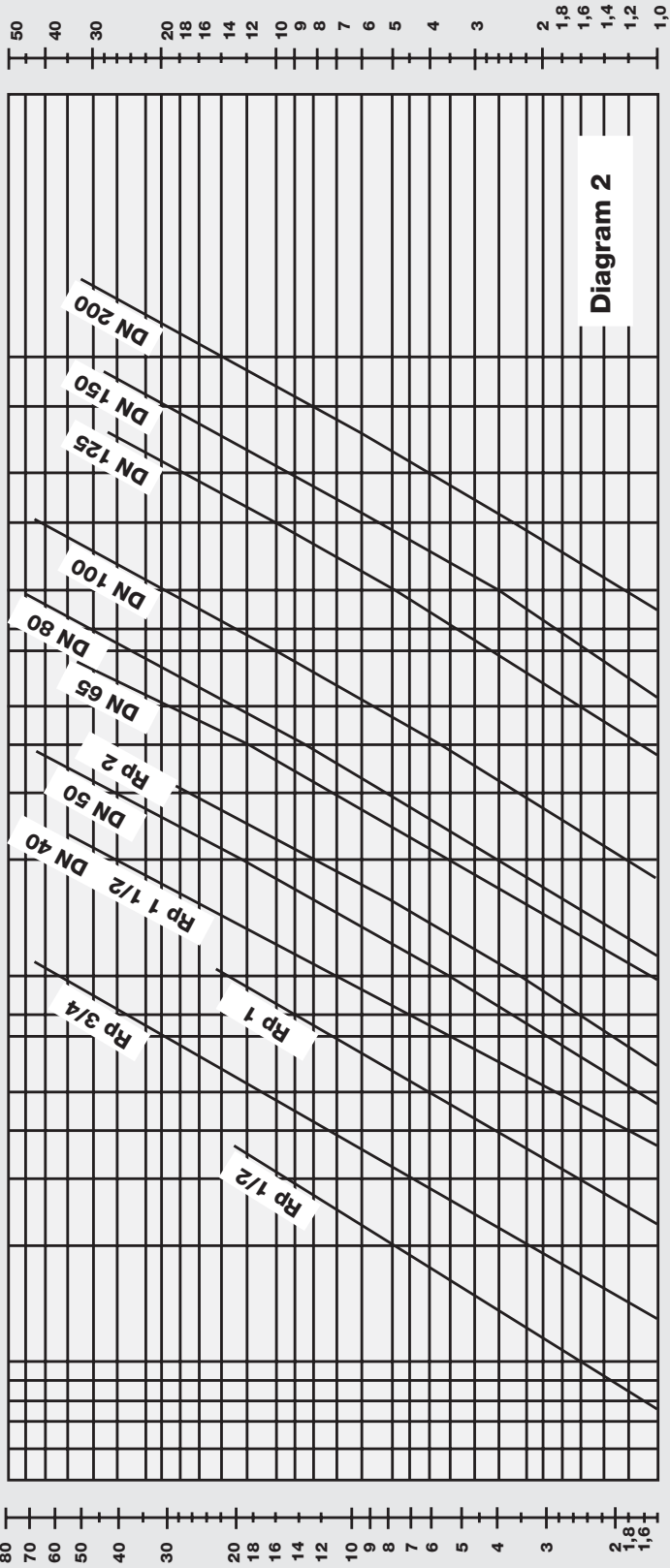

Pressure loss Δp [mbar] for air ($dv = 1$)

Inlet pressure p_e [bar]

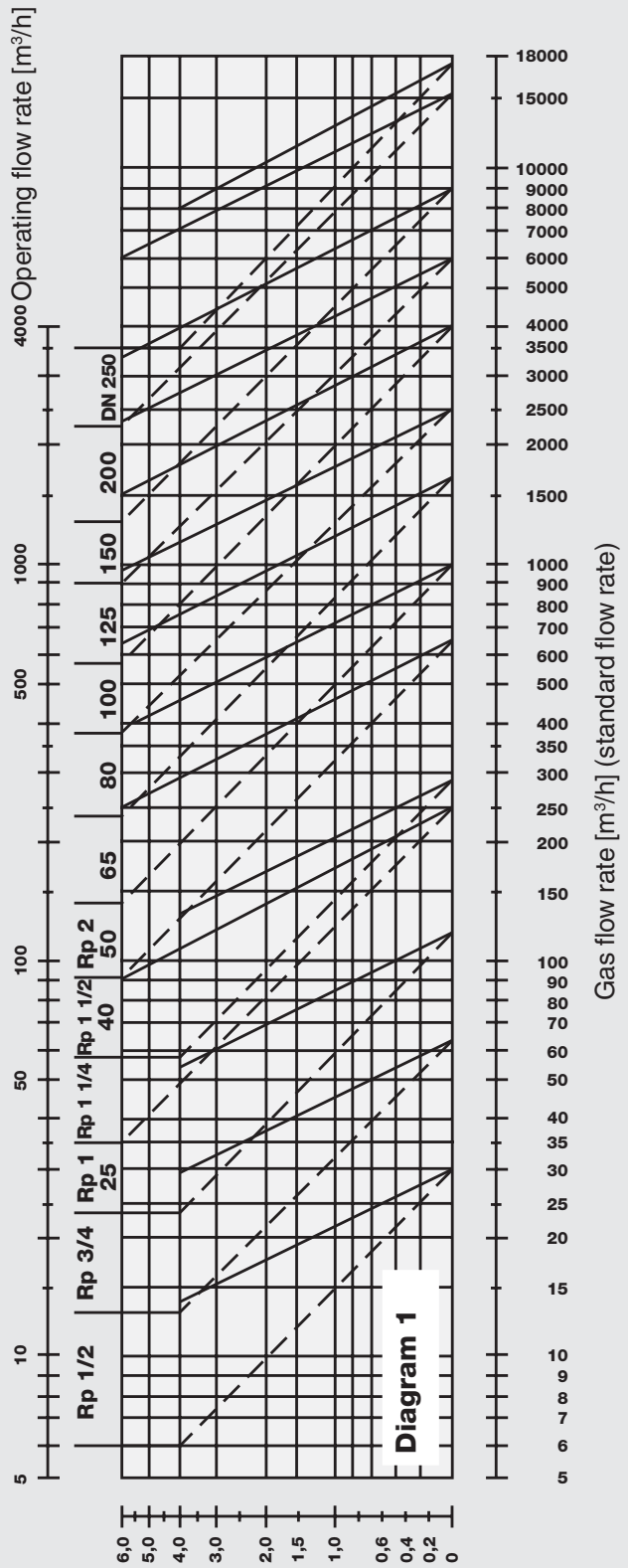

Diagram 1

- Determining the nominal diameter
- Conversion of the flow rate from standard flow rate to operating flow rate.

Diagram 2

- Determining the pressure loss (Δp).

Procedure

Determining the filter size

- 1.1 Define the flow rate as a standard flow rate on the lower scale.
- 1.2 Draw a parallel reference line along the diagonal dashed line up to the actual inlet pressure.
- 1.3 You will find region for minimum filter size vertically above this point of intersection. You can read the corresponding flow rate from the scale above.

Procedure

Determining the pressure loss

- 2.1 Define the flow rate as a standard flow rate on the lower scale.
- 2.2 Draw a parallel reference line along the diagonal dashed line up to the actual inlet pressure.
- 2.3 Go from this point of intersection vertically upwards to diagram 2. The pressure loss for gas and air can be read at the point of intersection with the characteristic curve for the previously determined filter size.

The pressure loss for other gases can be estimated from the value valid for air by multiplying this value with the density ratio.

All specified values refer to filter mats in new condition.

Example

Determining the filter size

- 1.1 Flow rate (standard flow rate)
2,000 m³/h
- 1.2 Inlet pressure 4 bar
- 1.3 Determining the filter size:
min. DN 100,
Determining the flow rate:
400 m³/h

Determining the pressure loss

- 2.1 Flow rate (standard flow rate)
2,000 m³/h
- 2.2 Inlet pressure 4 bar
- 2.3 Determining the pressure loss for gas: $\Delta p = 15$ mbar
Determining the pressure loss for air: $\Delta p = 23$ mbar

Example

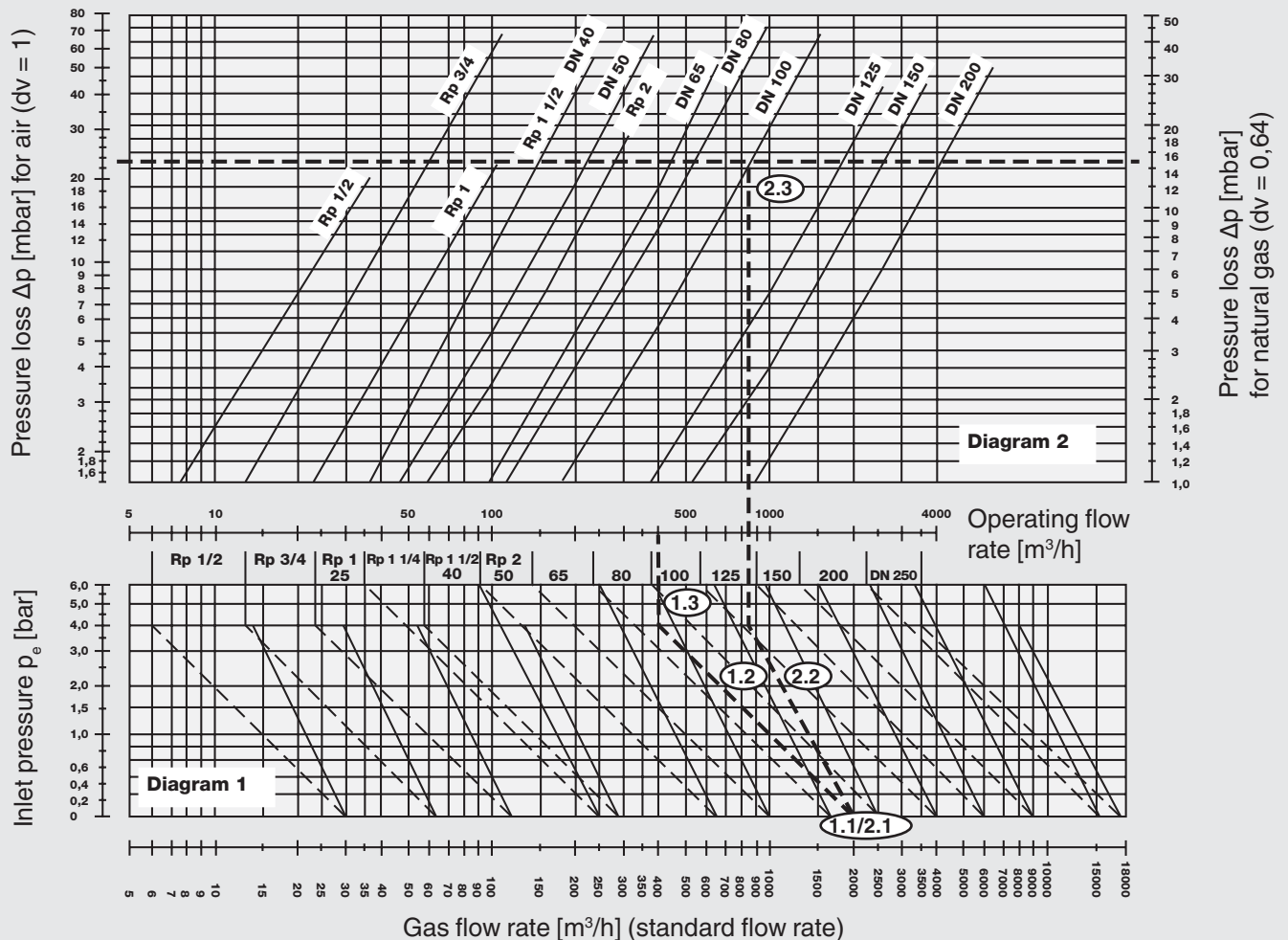

Gas and air filter

**GF/1
Rp 1/2 - Rp 2
GF/3
DN 40 - DN 100
GF
DN 125 - DN 200**

DUNGS®
Combustion Controls

We reserve the right to make any changes in the interest of technical progress.

**Head Offices and Factory
Karl Dungs GmbH & Co. KG
Siemensstraße 6-10
D-73660 Urbach, Germany
Telephone +49 (0)7181-804-0
Telefax +49 (0)7181-804-166**

**Postal address
Karl Dungs GmbH & Co. KG
Postfach 12 29
D-73602 Schorndorf, Germany
e-mail info@dungs.com
Internet www.dungs.com**