

## Pressure regulator FRNG

Zero pressure regulator  
Constant pressure regulator  
Compressed air-controlled pressure regulator

**DUNGS®**

4.14

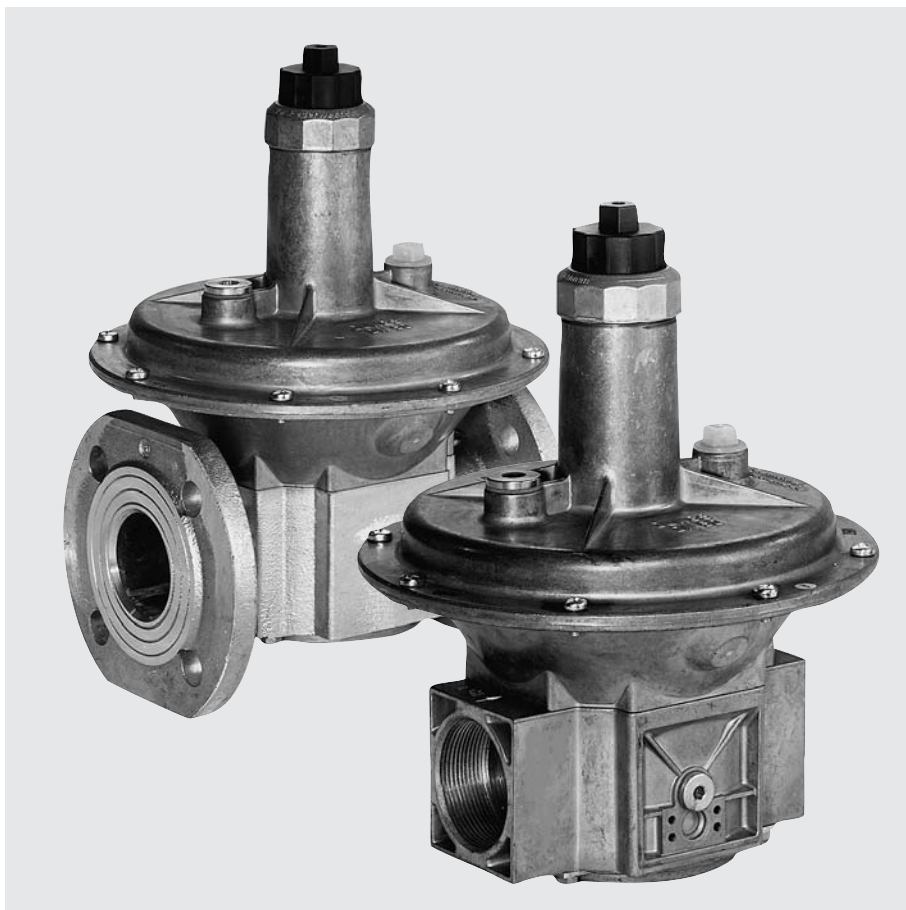

### Technical description

The DUNGS pressure regulator, type FRNG, has an adjustable setpoint spring and defined counterspring. The pressure regulator complies with EN 88 and DIN 3380:

- **Input pressures up to 50 mbar for zero pressure applications**
- **Input pressures up to 200 mbar for constant pressure applications**
- Bypass prepared, Rp 3/8 to Rp 2
- Sturdy, precise and sensitive regulation of regulator output pressure
- Inlet pressure compensation diaphragms
- Safety diaphragms
- Internal pulse for regulator output pressure as standard, external pulse connection prepared

- Connection for blower pressure as standard

### Application

The DUNGS pressure regulator, type FRNG, is suitable for gases of families 1, 2, 3 and other neutral gaseous media. Does not contain any non-ferrous metals, suitable for gases of up to max. 0.1 vol.% H<sub>2</sub>S, dry.

### Approval

EC type test approval as per EC Gas Appliance Directive:  
FRNG 5... CE-0085 AQ7126  
Approvals in other important gas consuming countries.

**FRNG** Spring-loaded pressure regulator with adjustable setpoint spring and defined counterspring. Internal tap of regulator output pressure, external pulse and blower pressure connections prepared. Suitable for controlling regulator output pressure via a pneumatic command variable.

## Specifications

Nominal diameters	DN 10 15 20 25 40 50 65 80 100 125 150
Pipe thread as per ISO 7/1	Rp 3/8 1/2 3/4 1 1 1/2 2
Flange	Connection flange per DIN 2501 Part 1, to fit preweld flange as specified in DIN 2633 (PN 16) DN 40 to DN 100, ISO 7005-2 (PN 16)
Max. operating pressure	up to 500 mbar (50 kPa)
Pressure regulator	Pressure regulator as per EN 88, Class A, Group 2, DIN 3380 RG 10, EN 12078
<b>Input pressure range</b>	
<b>Zero pressure regulator</b>	<b>5 to 50 mbar</b>
<b>Constant pressure regulator</b>	<b>5 to 200 mbar</b>
<b>Compressed air-controlled pressure regulator</b>	<b>to 500 mbar</b>
Output pressure range	Zero pressure regulator - 3 to 5 mbar Constant pressure regulator - 10 to 150 mbar Pressure with compressed air up to max. 300 mbar.
Materials of gas-conveying parts	Housing: aluminium, steel, no non-ferrous metals Seals and diaphragms: NBR
Ambient temperature	-15 °C to +70 °C
Installation position	Regulator dome from vertically upright to lying horizontally Rp 1/2 - DN 100 DN 125 -HS-, DN 150 -HS- with measuring unit type Measuring unit guide: Measuring unit with two guides for improved regulation when the regulator is installed with the regulator dome in horizontal position. -HS- = Horizontal Support Regulator dome in vertical position DN 125, DN 150
Measuring/ignition gas connections	G 1/4 ISO 228 on both sides in inlet section
Measurement opening	G 1/8 ISO 228 in the baseplate (option DN 125, DN 150) Reclosable opening for setting system-specific values when the system is put into operation, e. g. gas motor
Bypass	Bypass prepared: Rp 3/8 to Rp 2 on right of housing
Pulse connection	Internal in outlet section, externally prepared on housing: Rp 3/8 to Rp 1 left, G 1/8; on both sides from Rp 1 1/2, DN 40 G 1/4; internal pulse lockable
Blow-off line / pressure connection for blower pressure	Blow-off line needs no routing, use existing connection as pressure connection for command variable (blower pressure). Connection: G 1/4 to Rp 1; from Rp 1 1/2, DN 40: G 1/2
Blower pressure command variable	For constant pressure applications and gas-air ratio applications at pressure ratio of approx. 1:1 and in compressed-air controlled operation: $p_{\max} = 150 \text{ mbar}$

## Spring selection

The output pressure is provided by the force of the installed adjustable spring, the counterspring and the the blower pressure applied. The pressure regula-

tor is equipped with the brown spring No. 1 as standard. By exchanging the adjustable spring, it is possible to achieve larger positive zero point shifts

(offsets) of the output pressure (refer to Fig. Compressed air-controlled pressure regulator).

Setpoint spring range [mbar]	2.5...+9	5...13	5...20	10...30	25...55	30...70	60...110	100...150	140...200
Spring colour	Spring 1 brown	Spring 2 white	Spring 3 orange	Spring 4 bluw	Spring 5 red	Spring 6 yellow	Spring 7 black	Spring 8 pink	Spring 9 grey
Nominal diameter Rp/DN	Standard	Spring 2 to 9 for compressed air applications only							
Rp 3/8, Rp 1/2	229 817	229 818	229 821	229 821	229 822	229 823	229 824	229 825	229 826
Rp 3/4	229 833	229 834	229 836	229 836	229 837	229 838	229 839	229 840	229 841
Rp 1	229 842	229 843	229 845	229 845	229 846	229 847	229 848	229 849	229 850
Rp 1 1/2, DN 40	229 851	229 852	229 854	229 854	229 869	229 870	229 871	229 872	229 873
Rp 2, DN 50	229 874	229 875	229 877	229 877	229 878	229 879	229 880	229 881	229 882
DN 65, 80	229 883	229 884	229 886	229 886	229 887	229 888	229 889	229 890	229 891
DN 100	229 892	229 893	229 895	229 895	229 896	229 897	229 898	229 899	229 900
DN 125	229 901	229 902	229 904	229 904	229 905	229 906	229 907	229 908	243 416
DN 150	229 909	229 910	229 912	229 912	229 913	229 914	229 915	229 916	243 417

Standard Offset ≤ 5 mbar (Closing force of counterspring in closed position)

## Dimensions

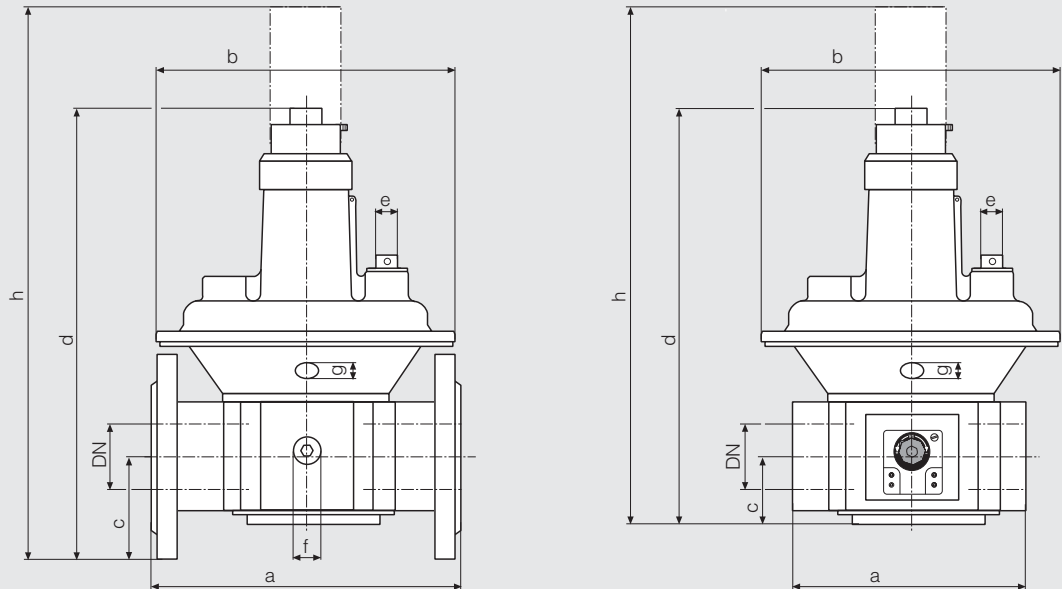

Type	Order No.	p <sub>max.</sub> [mbar]	Rp / DN	Dimensions [mm]								Weight [kg]
				a	b	c	d	e	f	g	h	
FRNG 503	220 967	500	Rp 3/8	75	115	24	143	G 1/4	G 1/4	G 1/8	225	0.60
FRNG 505	220 968	500	Rp 1/2	75	115	24	143	G 1/4	G 1/4	G 1/8	225	0.60
FRNG 507	220 969	500	Rp 3/4	100	130	28	165	G 1/4	G 1/4	G 1/8	245	1.00
FRNG 510	220 970	500	Rp 1	110	145	33	190	G 1/4	G 1/4	G 1/8	310	1.20
FRNG 515	209 064	500	Rp 1 1/2	150	195	40	250	G 1/2	G 1/4	G 1/4	365	2.50
FRNG 520	209 065	500	Rp 2	170	250	47	310	G 1/2	G 1/4	G 1/4	450	3.50
FRNG 5040	159 350	500	DN 40	200	195	65	280	G 1/2	G 1/4	G 1/4	395	3.50
FRNG 5050	209 067	500	DN 50	230	250	75	340	G 1/2	G 1/4	G 1/4	480	5.00
FRNG 5065	209 068	500	DN 65	290	285	95	405	G 1/2	G 1/4	G 1/4	590	7.50
FRNG 5080	209 069	500	DN 80	310	285	95	405	G 1/2	G 1/4	G 1/4	590	10.00
FRNG 5100	214 422	500	DN 100	350	350	105	495	G 1/2	G 1/4	G 1/4	760	16.00
FRNG 5125	220 758	500	DN 125	400	400	135	635	G 1/2	G 1/4	G 1/4	1000	28.00
FRNG 5150	224 212	500	DN 150	480	480	160	780	G 1/2	G 1/4	G 1/4	1180	38.00
FRNG 5125	243 265 -HS-*	500	DN 125	400	400	135	635	G 1/2	G 1/4	G 1/4	1000	28.00
FRNG 5150	243 266 -HS-*	500	DN 150	480	480	160	780	G 1/2	G 1/4	G 1/4	1180	38.00

**Bypass restrictor**  
Rp 3/8 - Rp2

225 256

\* -HS- Horizontal Support/  
Measuring unit guide

## Functional description

Functions according to the force comparison principle between the force of:

- the adjustable setpoint spring
  - the defined counterspring
  - the differential pressure at the working diaphragm
- and**
- the force due to weight of the moving parts

The counterspring acts against the adjustable spring and the weight due to force of the moving parts. Depending on the pretension of the adjustable spring and the installation position, the force of

the counterspring is compensated. Overcompensation leads to positive regulator output pressures, partial compensation leads to negative regulator output pressures.

## Instructions

Gas-conveying lines, pulse and connection lines must be made of steel and at least PN 1, DN 6. The lines must be resistant to thermal, chemical and mechanical loads. The lines must be durable and deformation- and crack-proof.

**⚠ Do not route condensate from lines into the pressure regulator.**

**⚠ Do not apply burning gas or combustion gas air mixtures to the installation chamber of the adjustable spring. Pressure regulators for this application on request.**

**FRNG 515 sectional drawing**  
**Pressure regulator in closed position**

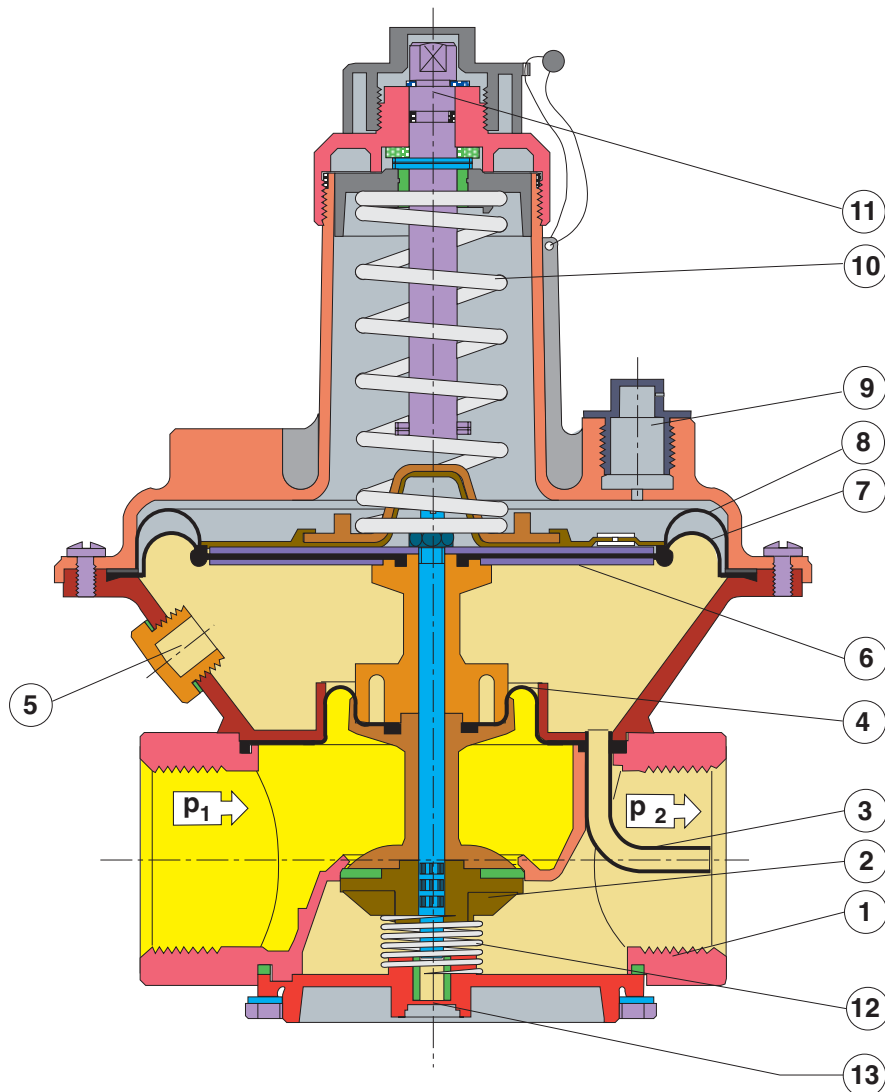

1	Housing	6	Diaphragm disk	11	Adjustment device
2	Regulating cup	7	Working diaphragm	12	Counterspring
3	Pulse tap, internal	8	Safety diaphragm	13	Option DN 125, DN 150
4	Compensation diaphragm	9	Breathing plug		Measurement opening with
5	External pulse	10	Setpoint spring		screw plug G 1/8

### Application of zero pressure regulator (standard design)

The FRNG regulates a gas flow proportional to the consumer vacuum for gas motors and self-intaking gas equipment.

The regulator is adjusted within the setting range at the setpoint spring.

$$\dot{V}_{\min.} = \dot{V}_{\max.} \times 0.1$$

For  $\dot{V}_{\max.}$ , see volumetric flow pressure drop characteristic.

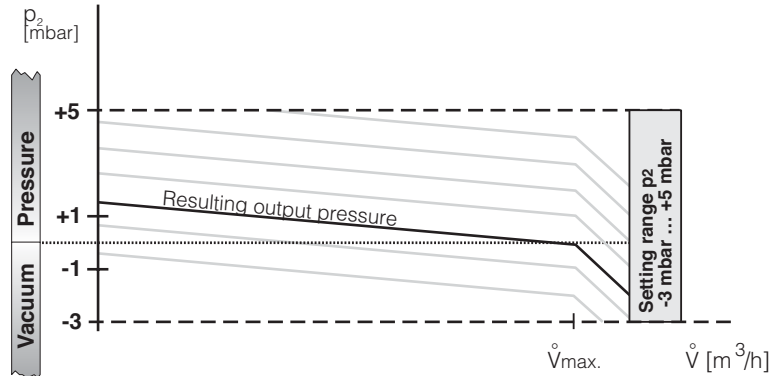
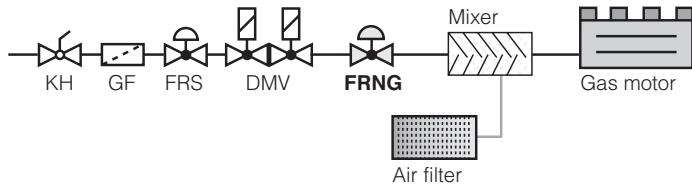

### Application with compressed air-controlled pressure regulator (standard design)

For externally controlled gas equipment.

In connection with a selected setpoint spring, the regulator output pressure can be controlled depending on the blower pressure (compressed air). The command variable can be up to +150 mbar.

$$\dot{V}_{\min.} = \dot{V}_{\max.} \times 0.05$$

For  $\dot{V}_{\max.}$ , see volumetric flow pressure drop characteristic.

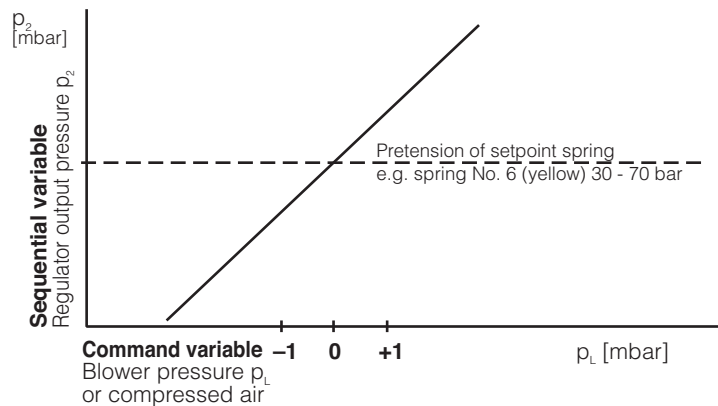
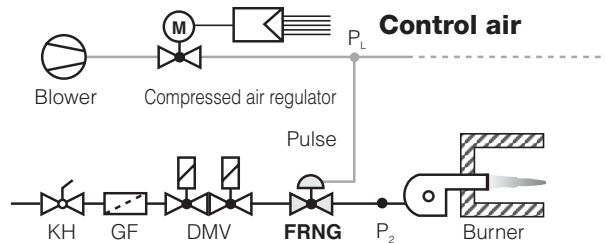

### Pressure taps Pulse and blower connection

- 1 Breathing plug **or** connection for blow-off line. Only route blow-off line in special cases **or** connection for air pulse line
- 2 Connection for external gas pulse. Internal pulse must be closed.
- 3 Pressure connection in inlet section G 1/4 ISO 228 screw plug, Rp 3/8 to Rp 2 with bypass cover prepared for mounting adjustable bypass restriction.

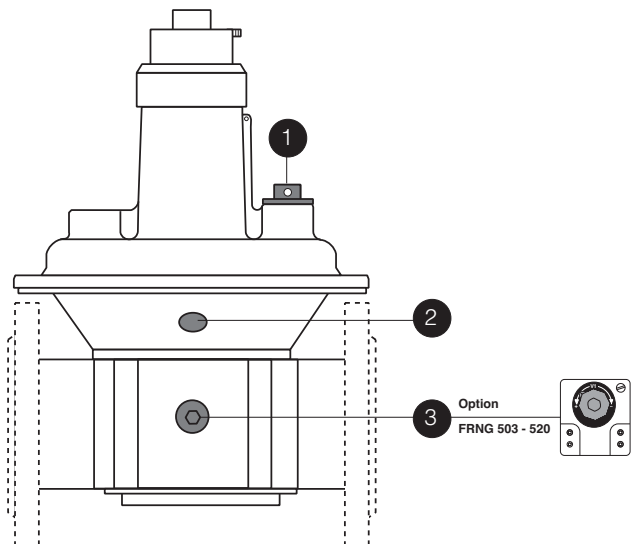

### Application of constant pressure regulator (standard design)

As constant pressure regulator for gas-air ratio regulators with fixed efficiency pressure ratio  $V = 1:1$  on gas equipment operated with differential pressure.

The offset range of the counterspring can be set by the setpoint spring. The moving parts are compensated by the force due to weight.

Gas supply or air supply are adjustable at full load and partial load.

Basic load is adjustable via bypass restrictor.

The command variable can be up to +150 mbar.

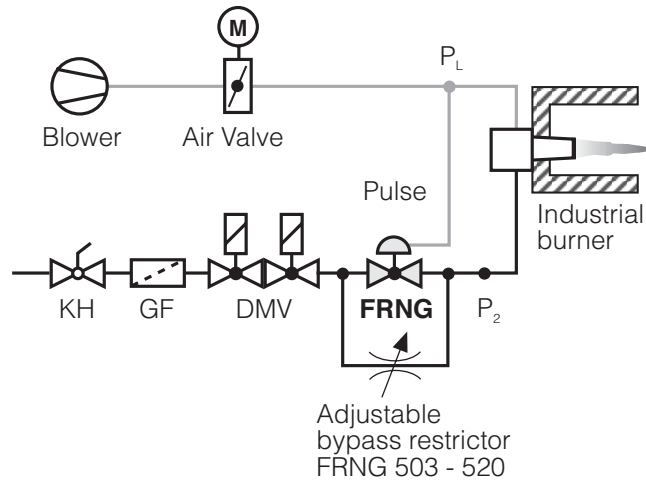

**!**  $\dot{V}_{min.} = \dot{V}_{max.} \times 0,05$

For  $\dot{V}_{max.}$ , see volumetric flow pressure drop characteristic.

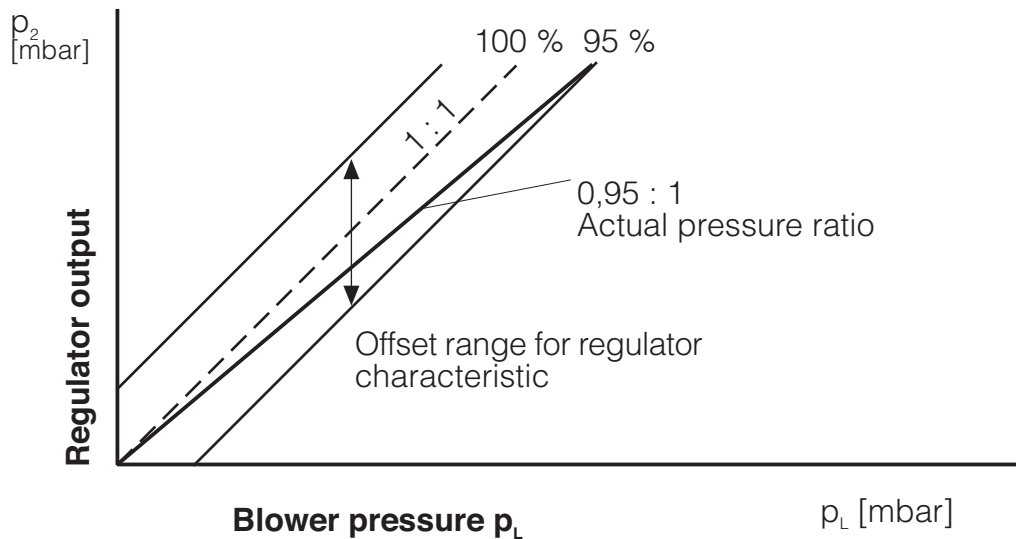

**Volumetric flow pressure difference characteristic  
Bypass restrictor**

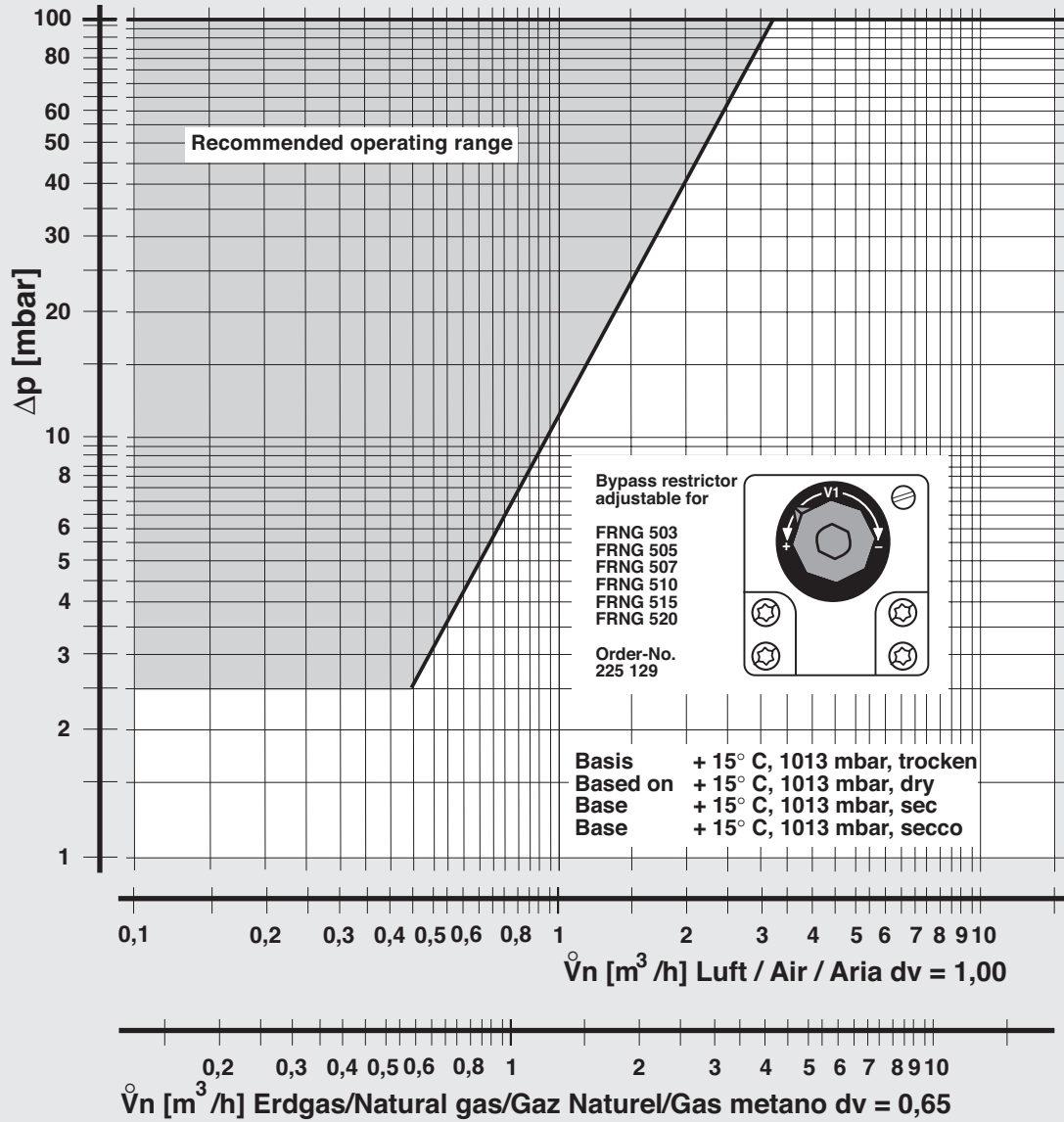

**Pressure regulator  
FRNG**

**Zero pressure regulator  
Constant pressure regulator  
Compressed air-controlled  
pressure regulator**

**DUNGS®**

**Volumetric flow pressure loss characteristic**

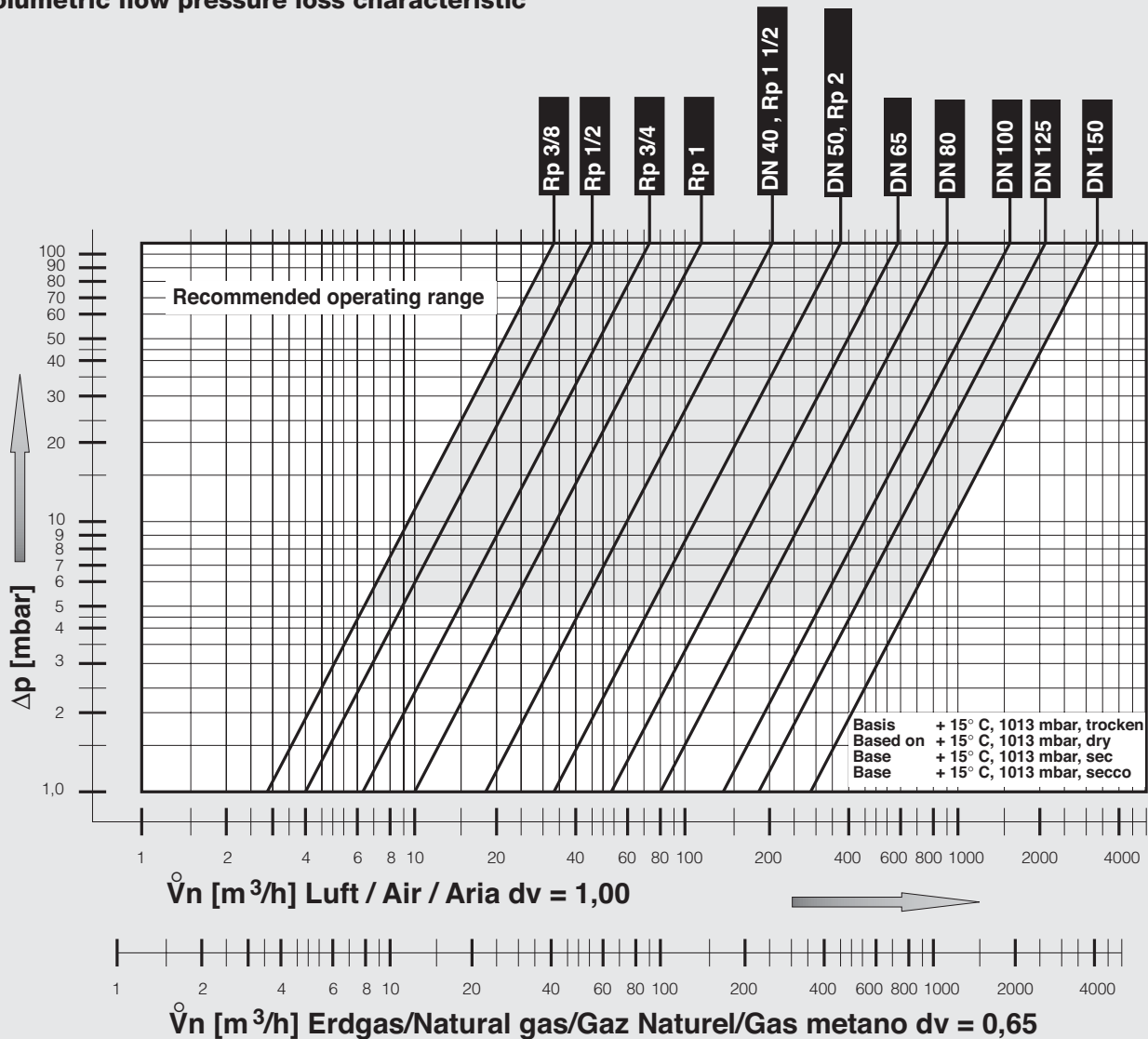

We reserve the right to make any changes in the interest of technical progress.

**Head Offices and Factory  
Karl Dungs GmbH & Co. KG  
Siemensstraße 6-10  
D-73660 Urbach, Germany  
Telephone +49 (0)7181-804-0  
Fax +49 (0)7181-804-166**

**Postal address  
Karl Dungs GmbH & Co. KG  
Postfach 12 29  
D-73602 Schorndorf, Germany  
e-mail info@dungs.com  
Internet www.dungs.com**